

RF ↔ SYSTEM

PMSDR

Software Defined Radio

- Modification notes to reduce spures and the Zerof-noise -

This modification are applicable on all PMSDR 2.12x board releases.

The main goal of this modification is the reduction of the zerof-noise and some spures across the most bands.

Note: The results of this modification described below can be vary on some systems. This depend from the soundcard and the USB Host controller. The discribed results was achieved with the PMSDR on a EMU-0202 soundcard and a HP XW4400 workstation.

Part List:

2 pcs. 100uF/16V polarized capacitor (radial, diam.: about 5mm) Mouser p.n. 667-EEU-FR1C101B or similar

2 pcs. 1000uF/6,3V polarized capacitor C85/C86 Mouser p.n. 647-UVZ0J102MPD or similar

1 pcs. 470 uH SMD inductor (Kemet L1007C471KPWST) Mouser p.n. 80-L1007C471KPWST

1 pcs. 10kOhm SMD resistor 0805

Note: The 470 uH SMD inductor can also be replaced by a 10-Ohm resistor, but with less noise reduction as result.

Copyright 2011 RF-SYSTEM ©

<http://www.rfsystem.it> , Italy

PMSDR

- Noise floor @ 7MHz without modification, antenna input open -

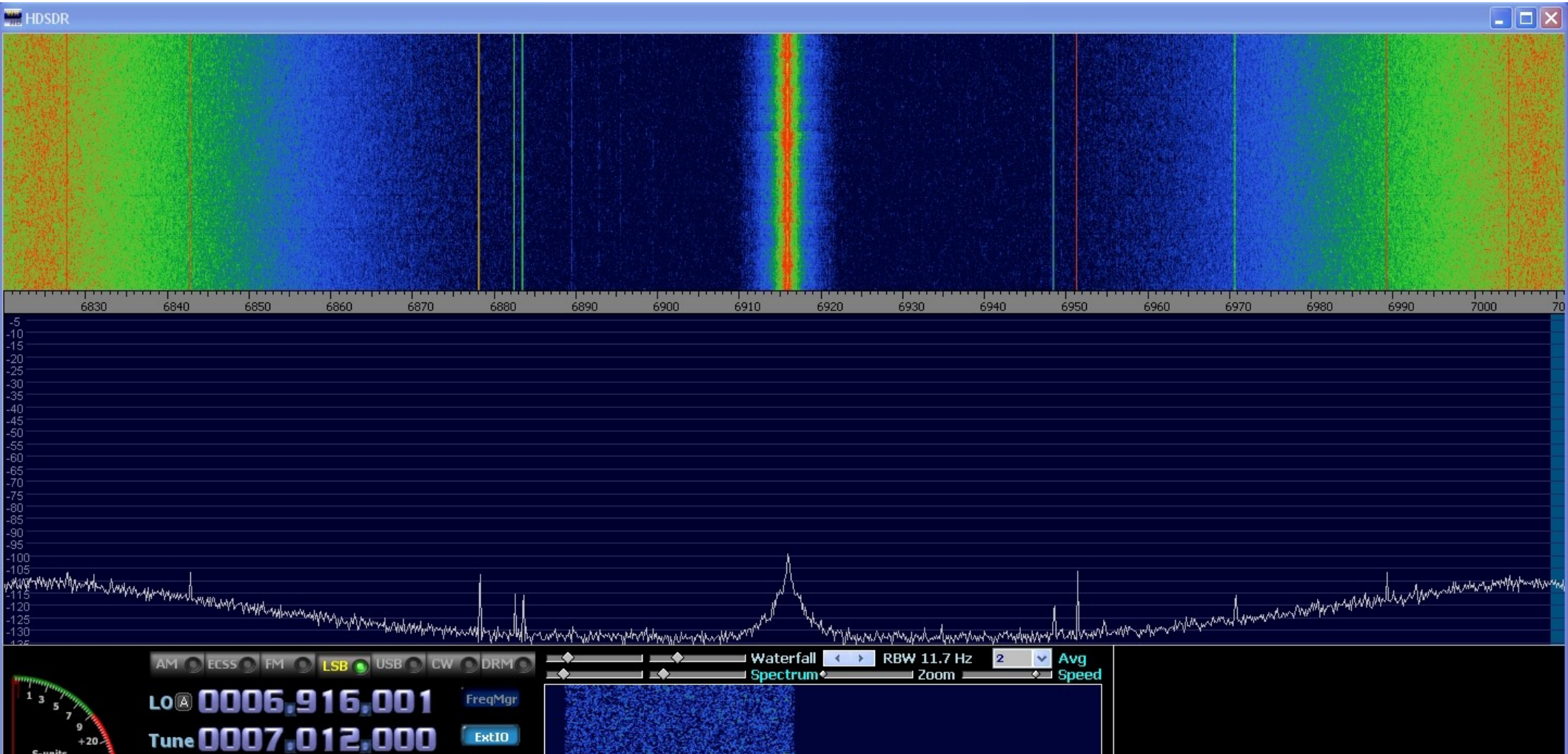

PMSDR

- Noise floor @ 7MHz with modification, antenna input open -

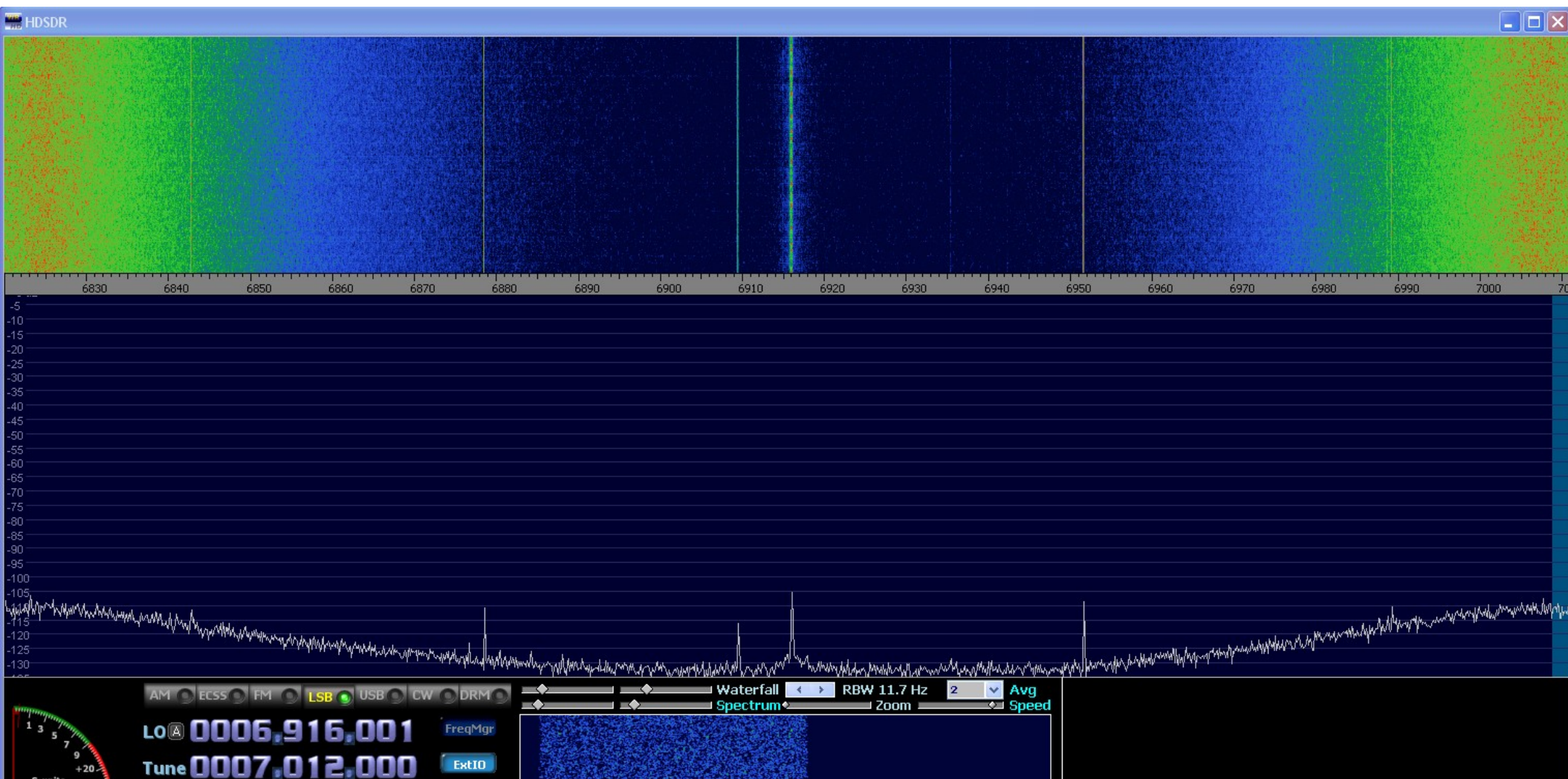

PMSDR

- Noise floor @ 50MHz without modification, antenna input open -

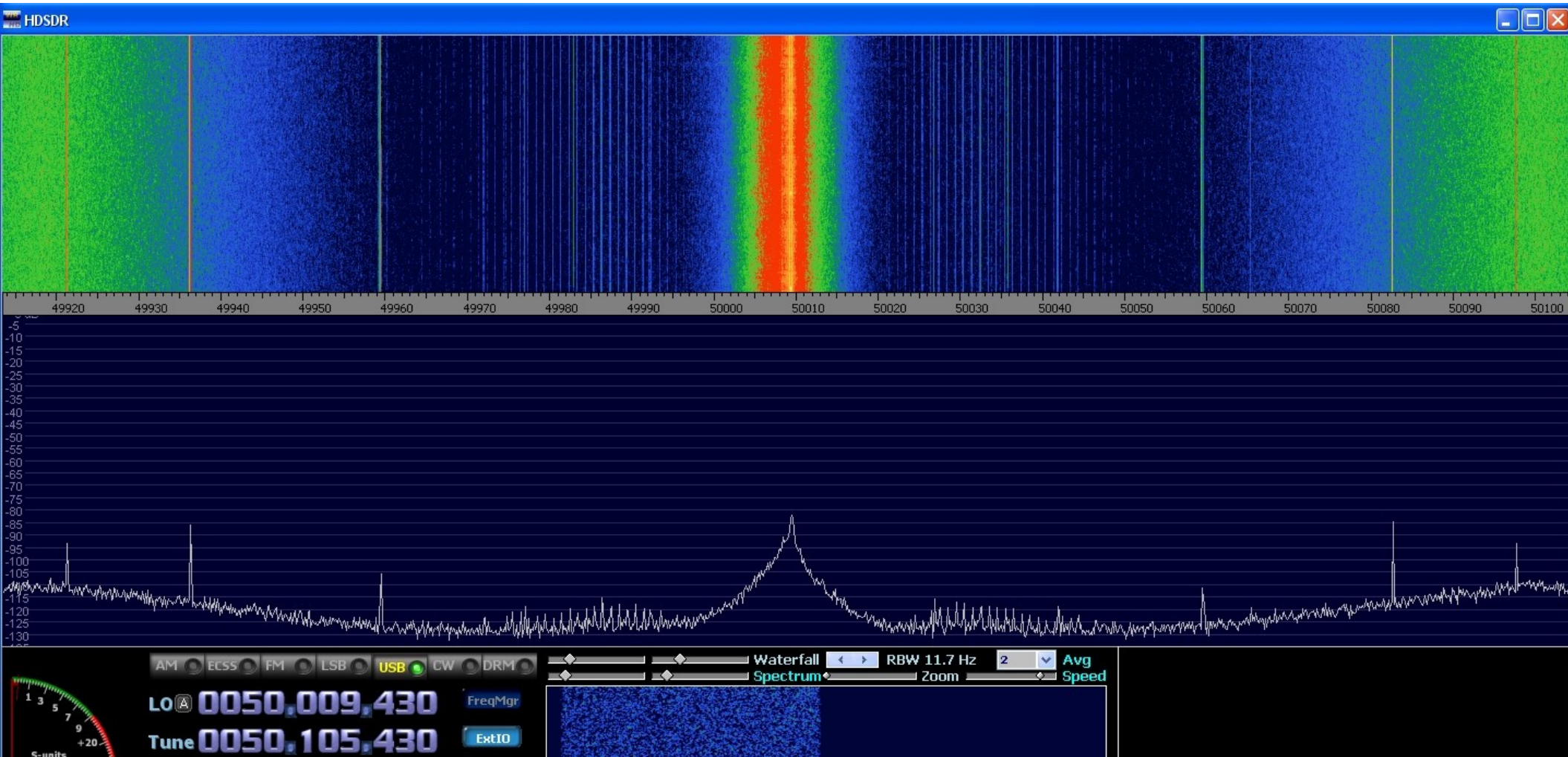

PMSDR

- Noise floor @ 50MHz with modification, antenna input open -

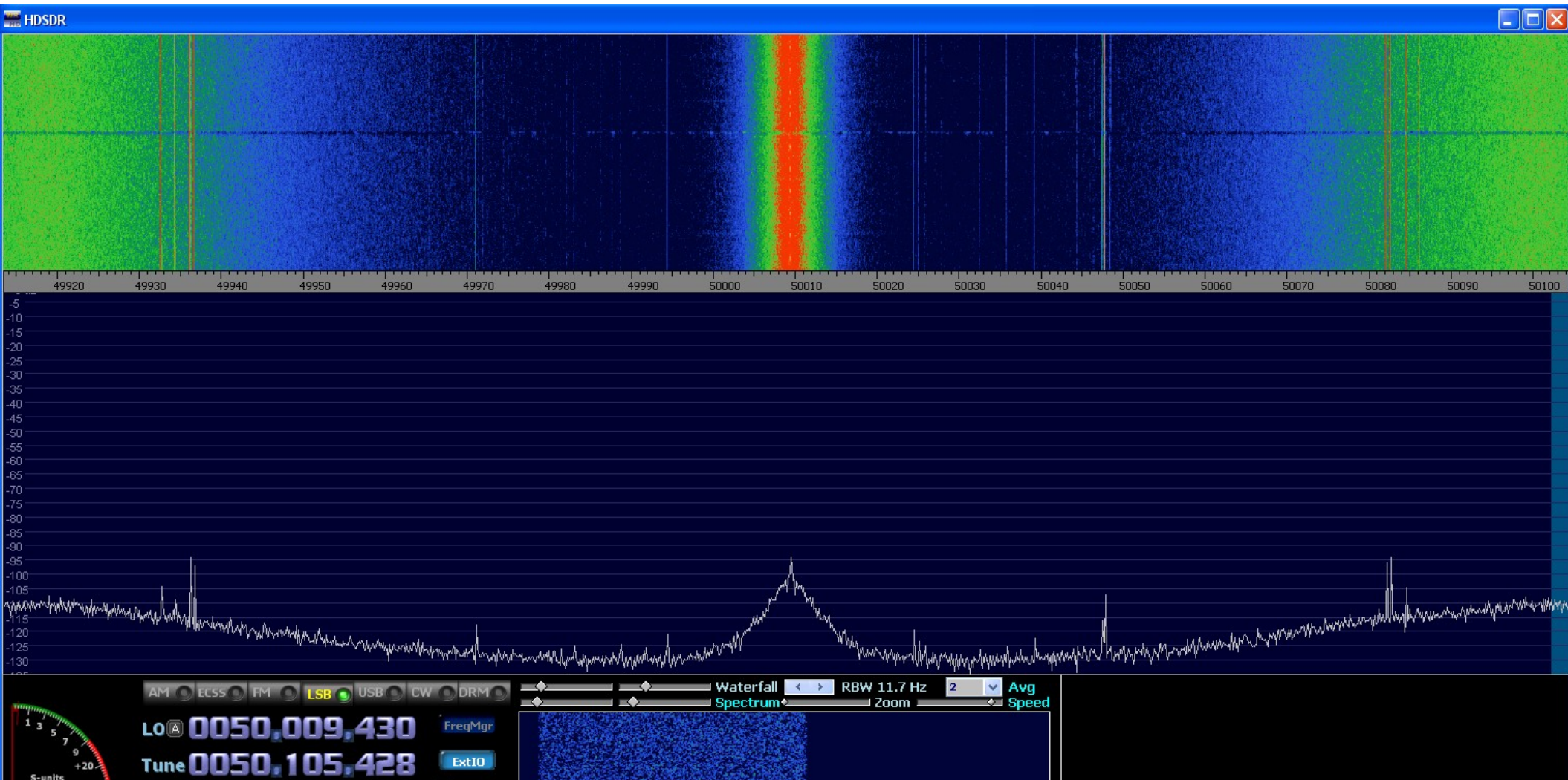

PMSDR

- *Modification instruction notes* -

**Add C83
across
C74**

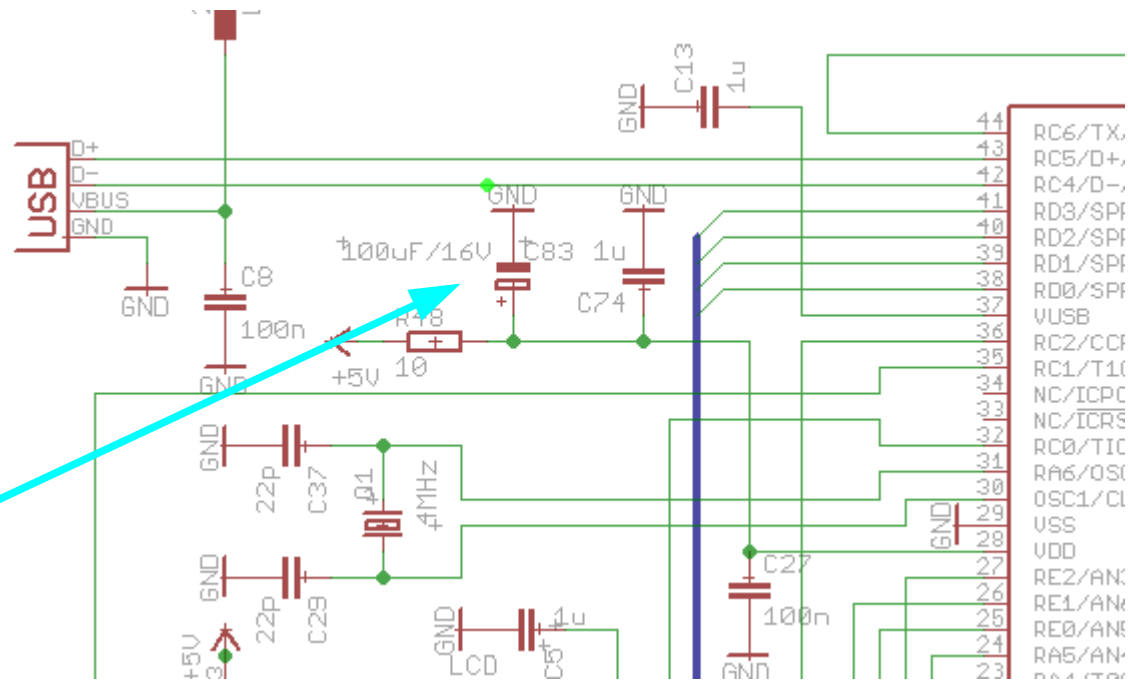

PMSDR

- *Modification instruction notes* -

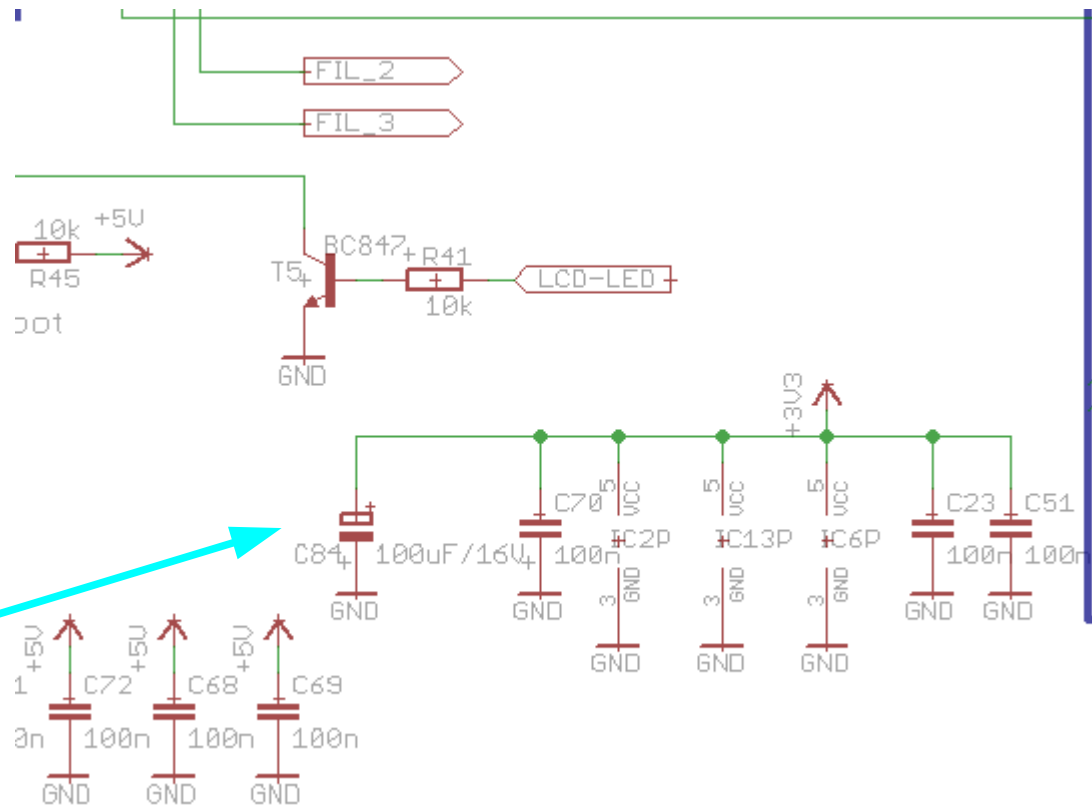

**Add C84
across
C51**

PMSDR

- *Modification instruction notes* -

Add L19

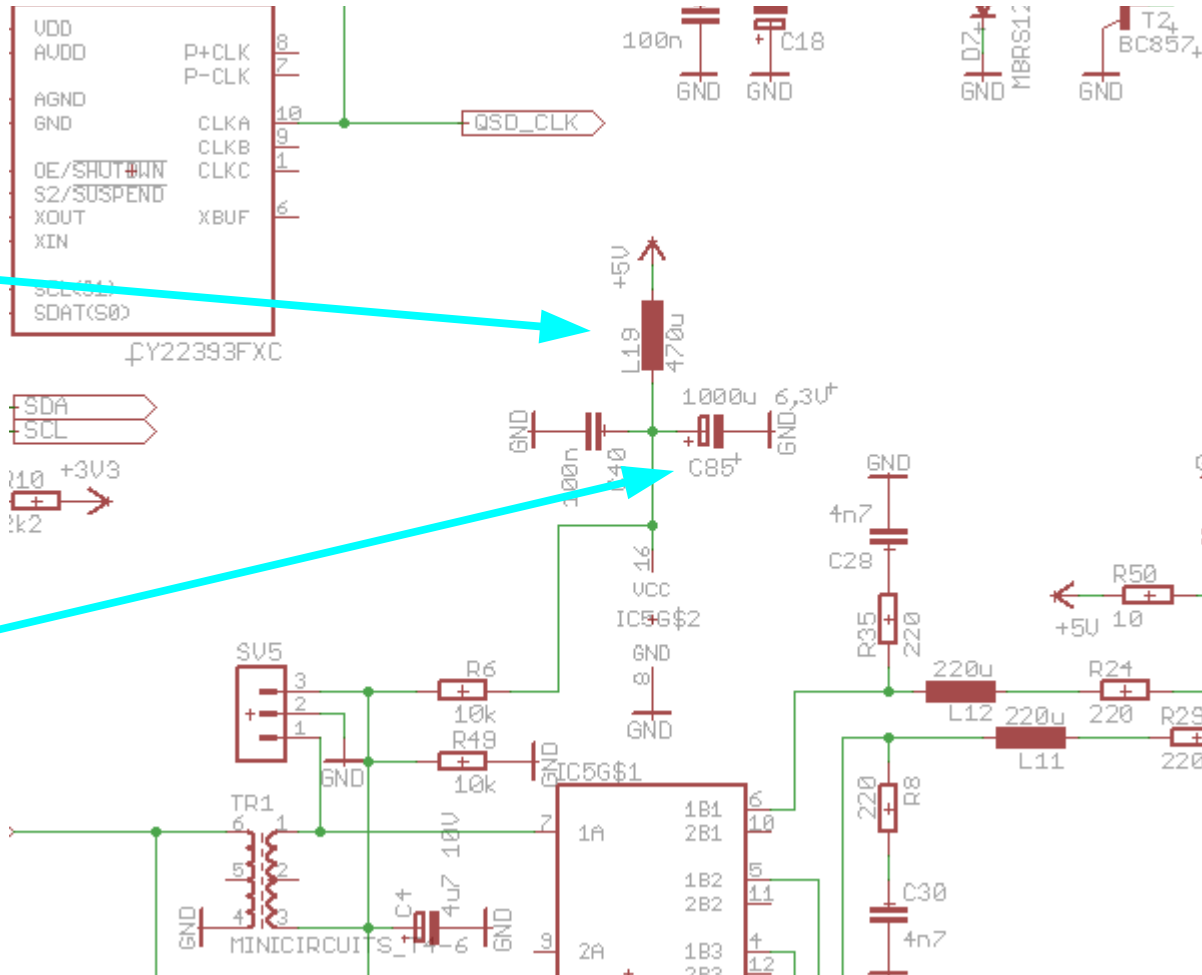

**Add C85
across
C40**

PMSDR

- *Modification istruction notes* -

**Remove
T4**

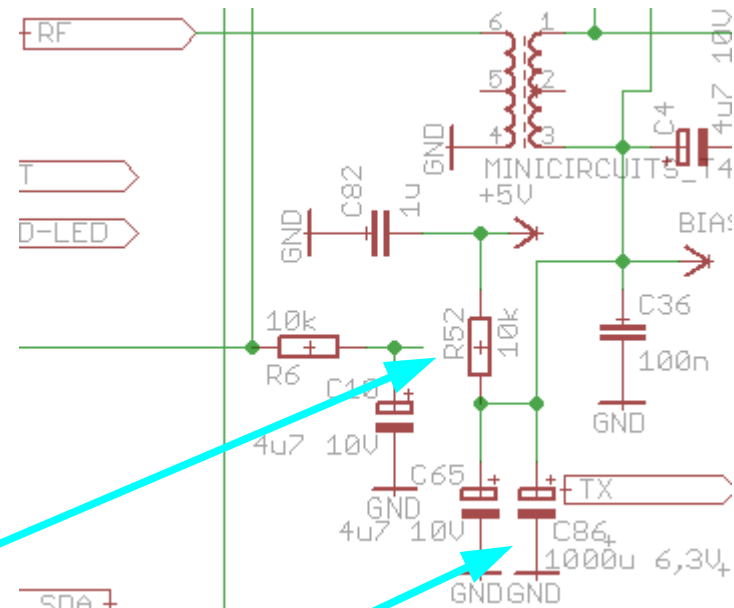
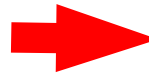
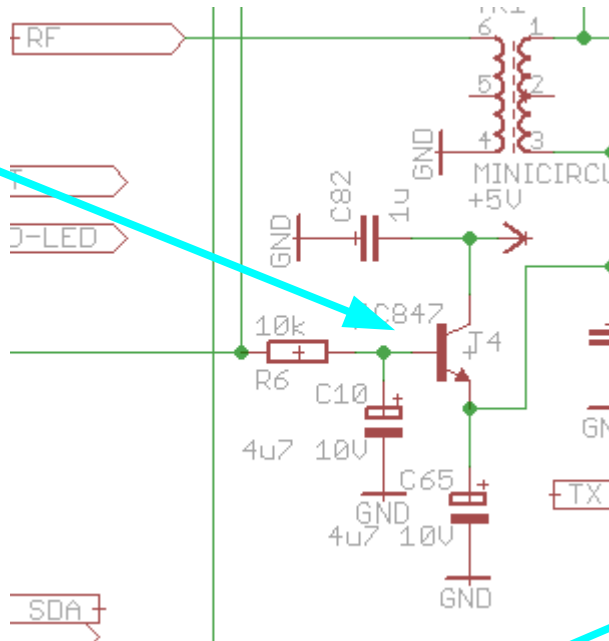

**And place R52
between C-E
pads of T4**

**Add C86
across
C65**

PMSDR

- *Modification instruction notes* -

1) Cut
the trace
here

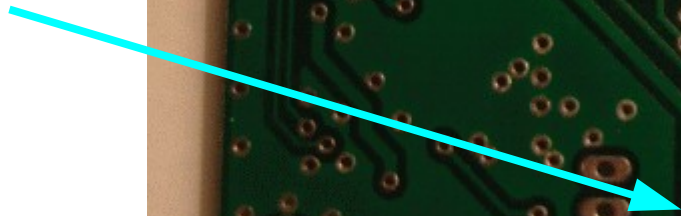

PMSDR

- *Modification instruction notes* -

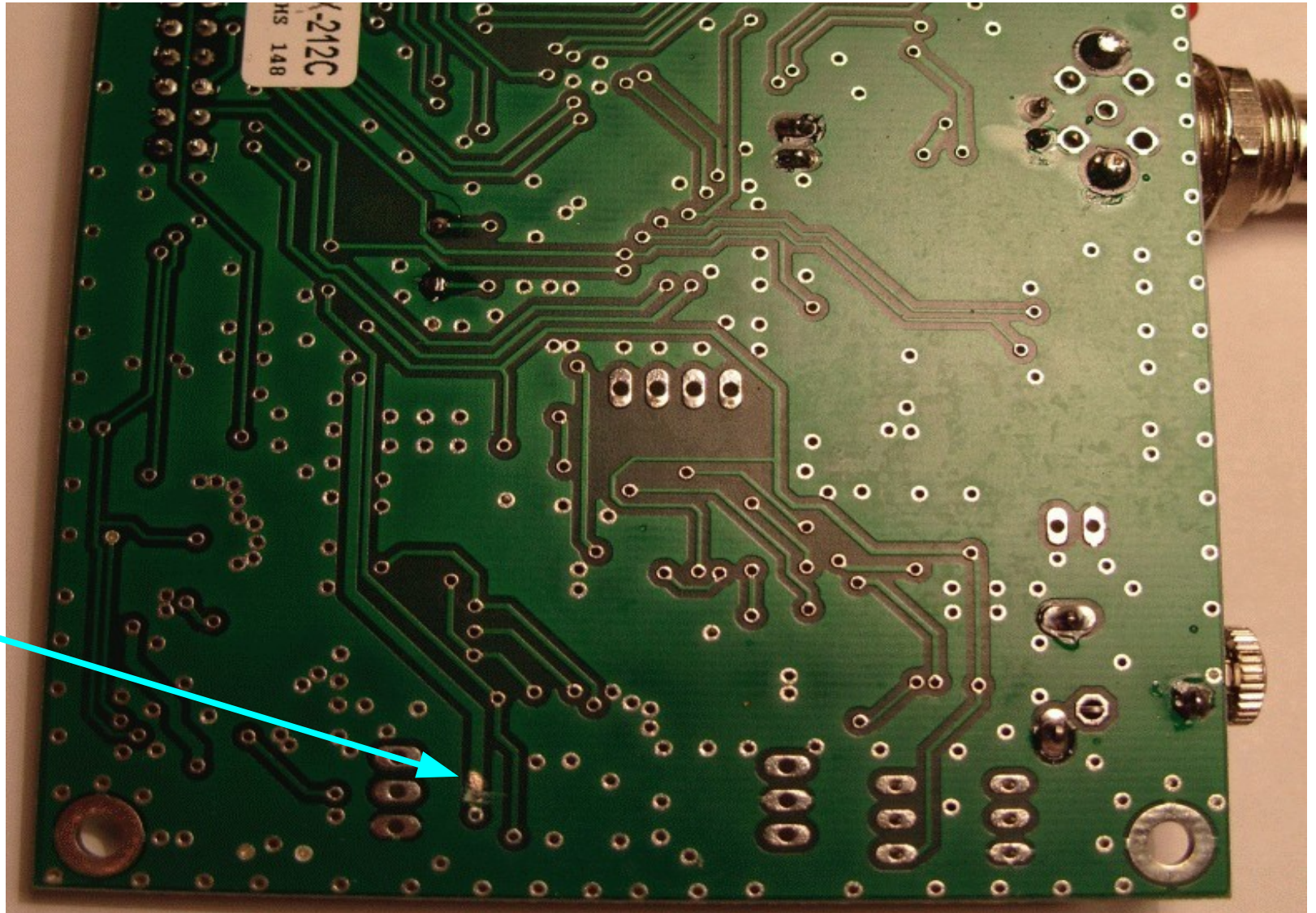

2)
Remove
the green
solder
mask

PMSDR

- *Modification instruction notes* -

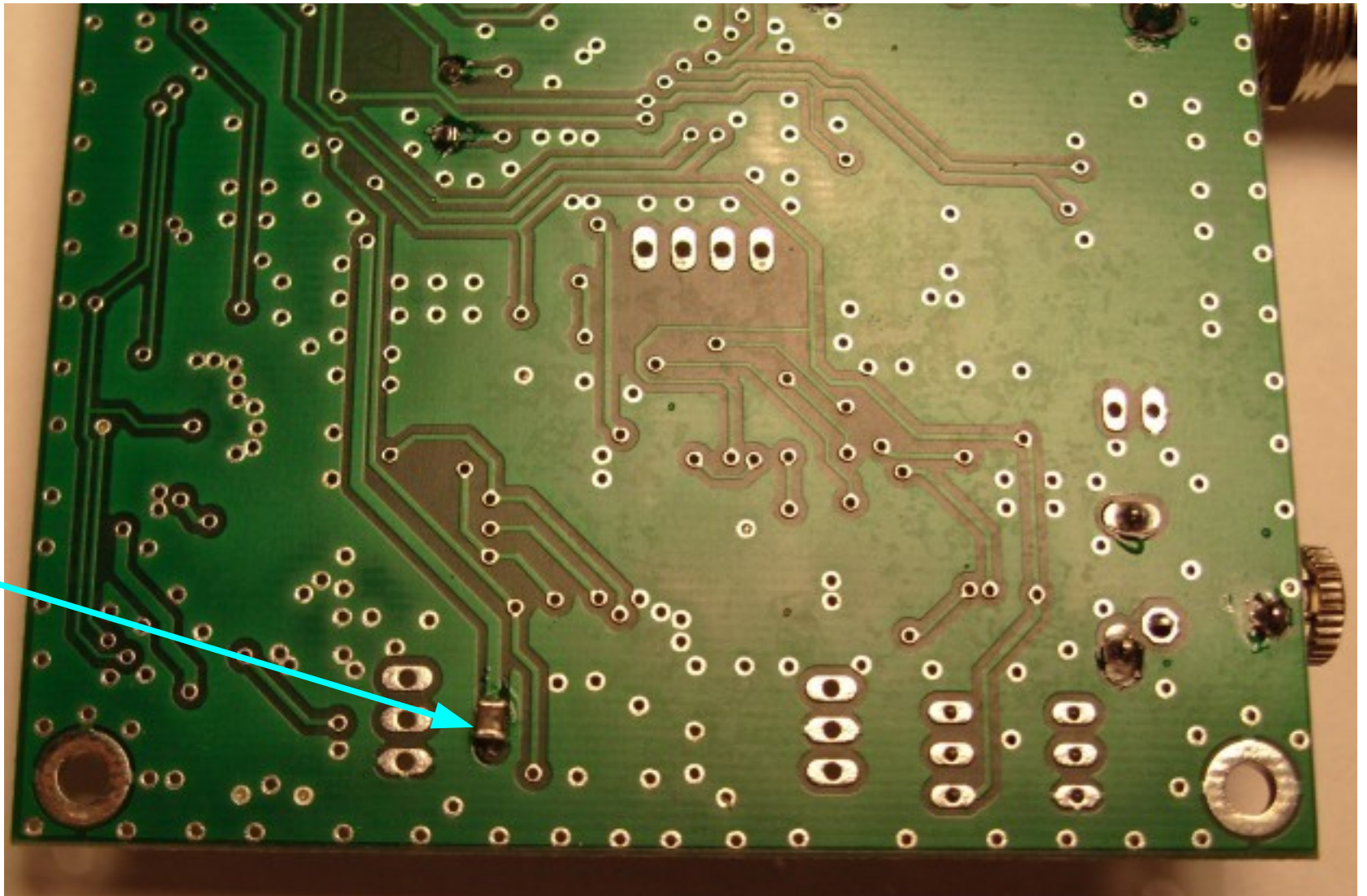

**3) Solder
the SMD-
inductor
here**

PMSDR

- *Modification instruction notes* -

4) Solder the polarized capacitors. **IMPORTANT:** pay attention about the capacitor polarization!

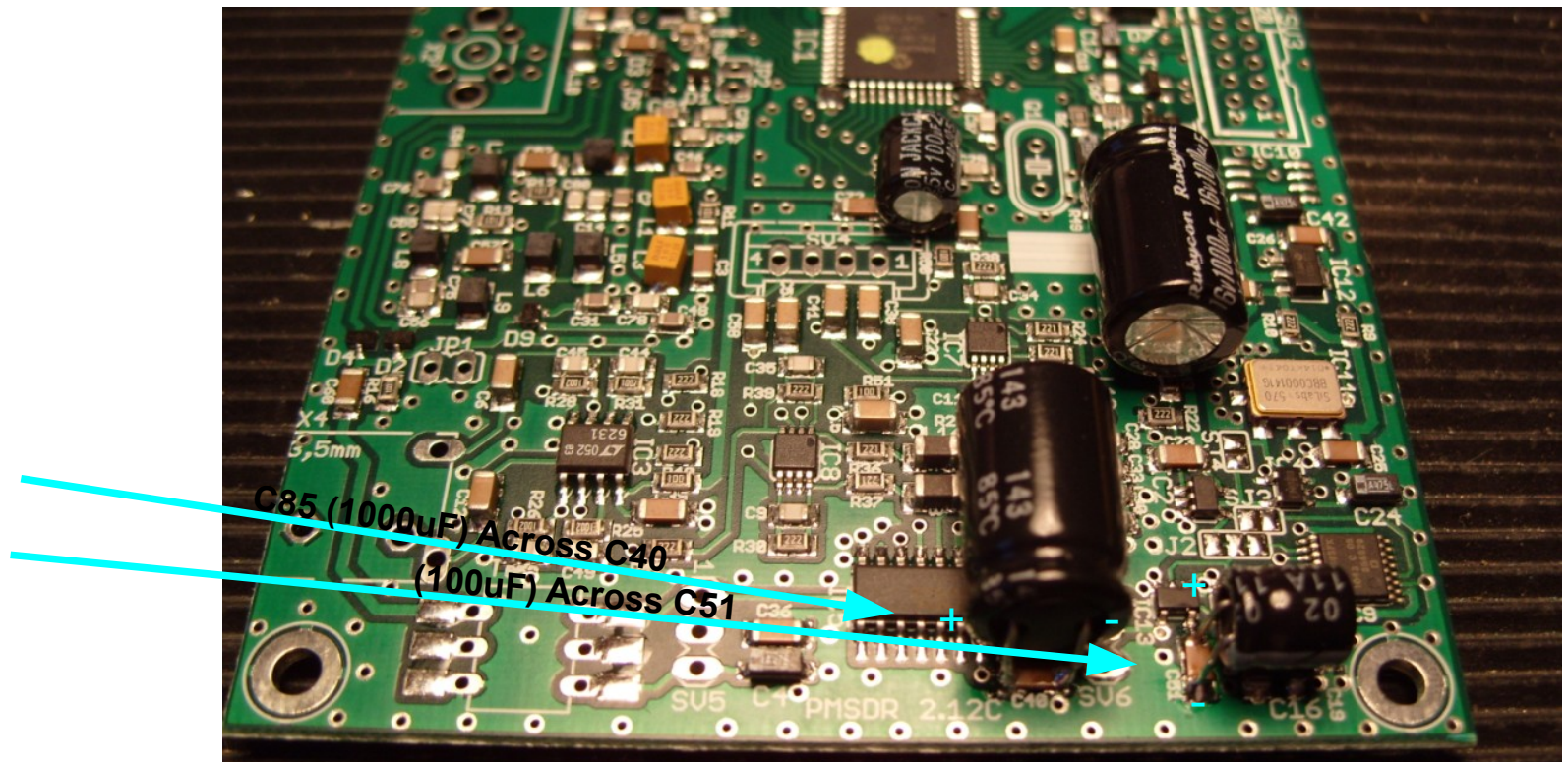

PMSDR

- *Modification instruction notes* -

5) Solder the polarized capacitors. **IMPORTANT:** pay attention about the capacitor polarization!

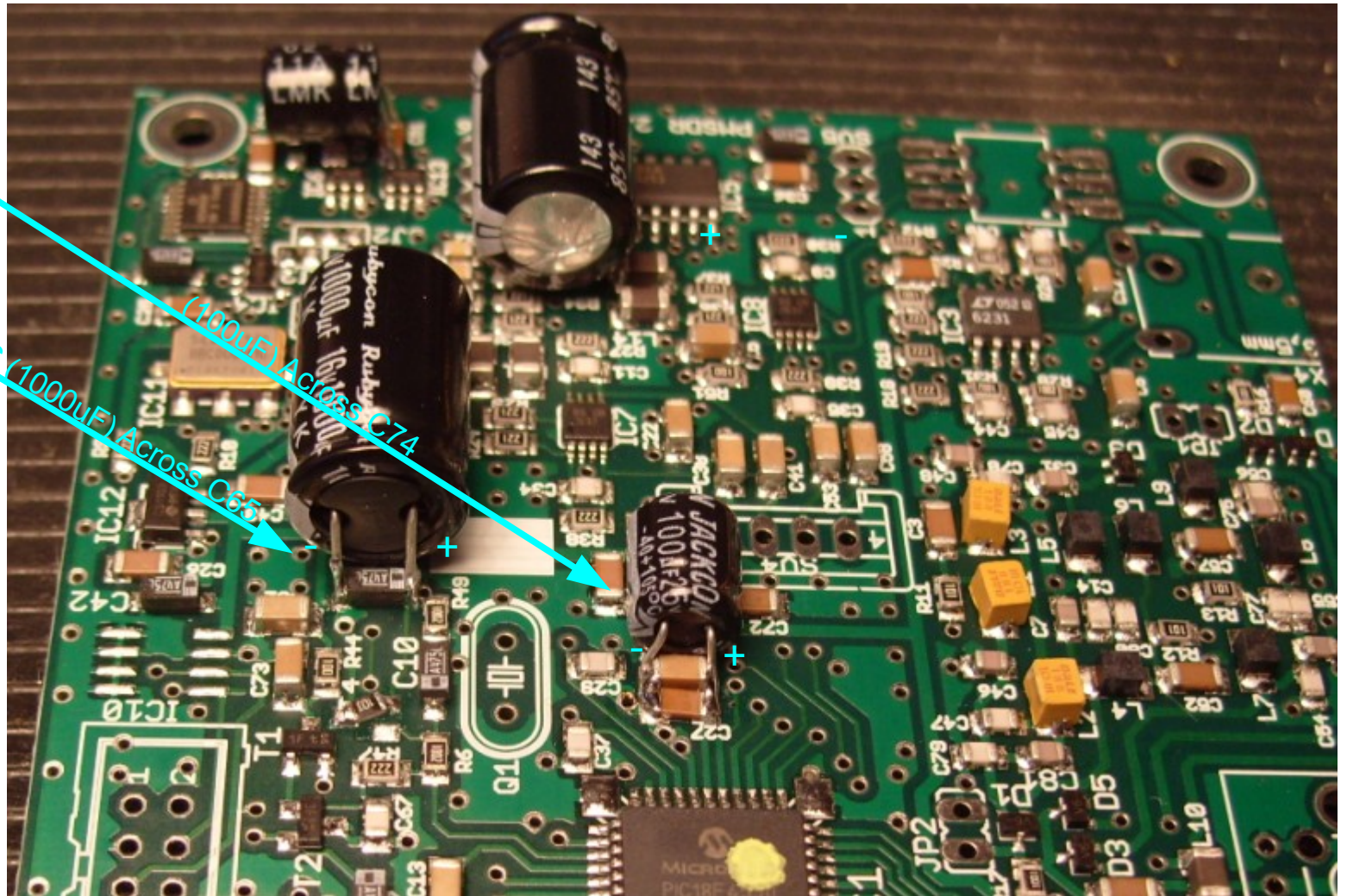

PMSDR

- *Modification instruction notes* -

6) Remove T4
and place
R52

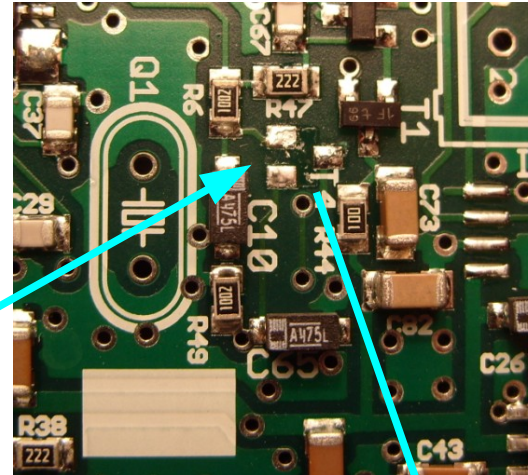
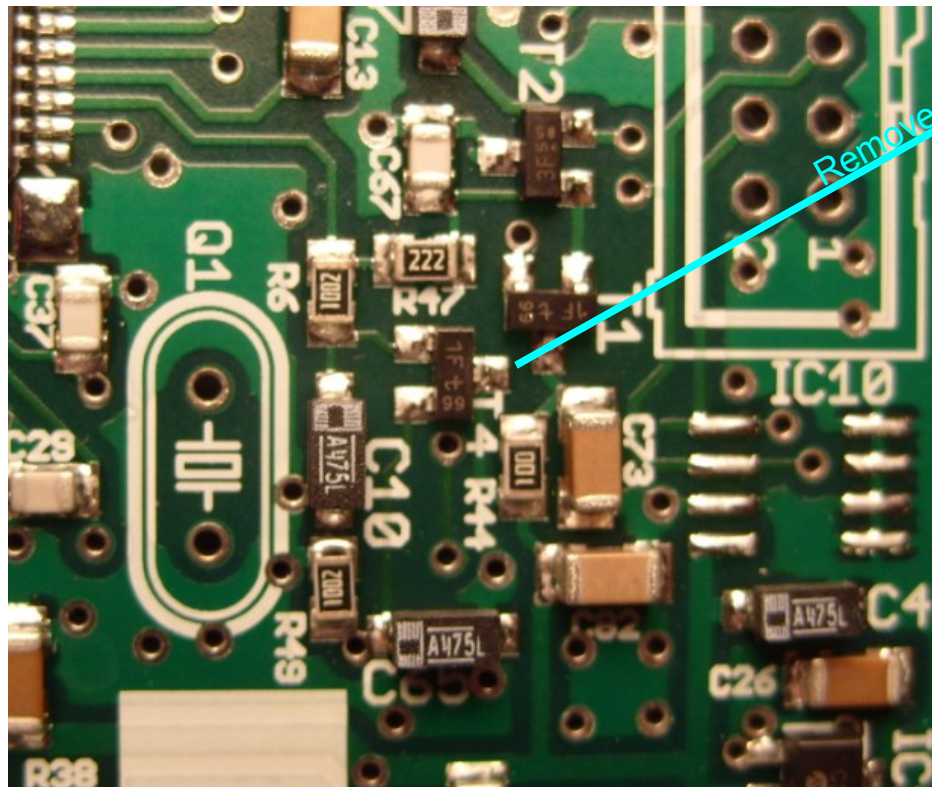

R52 (10kOhm) instead of T4

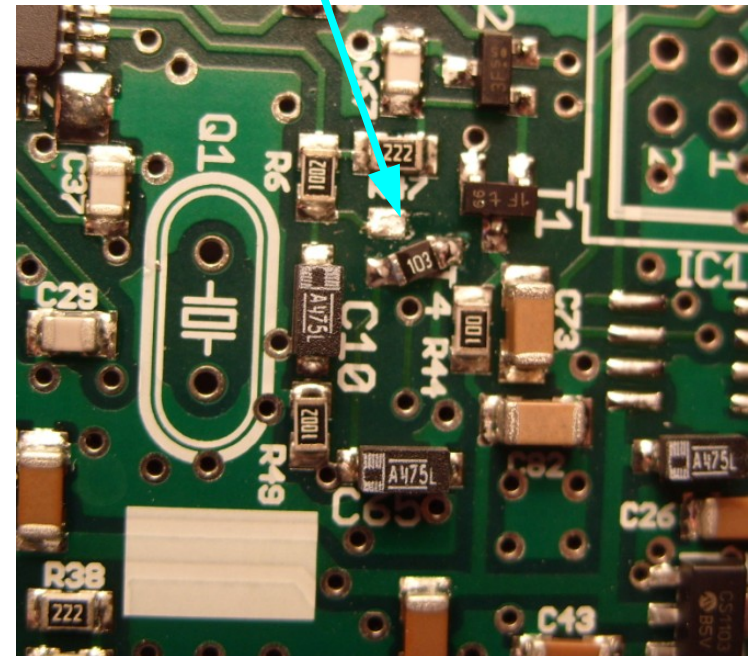

PMSDR

- *Modification instruction notes* -

7) Test notes:

- The voltage across C85 should be about 4,8V (this value depend from the USB supply voltage)
- The voltage across C86 should be about 2,4V (4,8V/2)